

22 φ AD indicator light series



Product manual :

Applicable environment

Ambient temperature: $-25^{\circ}\text{C} \sim +55^{\circ}\text{C}$.

Air relative humidity $\leq 98\%$.

It can normally work in the case of vibration frequency is 2-80Hz and the acceleration is 0.7g.

Pollution level of 3, The installation type is III 類 type.

Performance parameters

Withstand voltage: 2.5KV, 1min

Insulation resistance: $\geq 2\text{M}\Omega$

AC allows voltage fluctuations $\pm 20\%$

Continuous working life ≥ 50000 小時

Brightness $\geq 200\text{cd}/\text{m}^2$

Comparative Tracking Index CTI ≥ 100

Head protection class IP65 can order IP67





Usage frequency AC 50~60Hz

Complies with CE certification

Origin: Taiwan

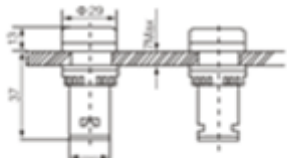

Specification :

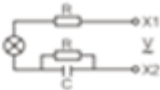
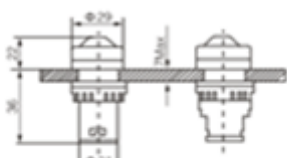
Appearance	model	colour	voltage	Electrical principle	size
		<ul style="list-style-type: none"> ● red ● green ● yelos ● blue ○ white 		 <p>交流/直流 (AC/DC)</p>	
		○ white		 <p>交流型 (AC)</p>	

Model Description

AD1622①②③

① R=red/G=green/Y=yellow/W=white/S=blue

② 12=12V/24=24V/110=110V/220=220V(DC/AC shared)

③ N=normal brightness/H=high brightness

Printing style

AD1622□□H

High brightness

AD1622□□N

Normal brightness

For example: AD1622R220H is 220V and red high brightness.